

Operation Instruction

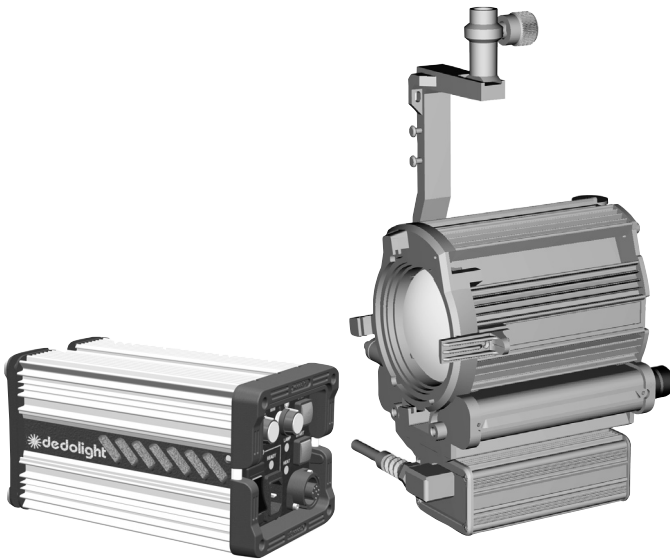

**DEB 400D ELECTRONIC BALLAST
DLH 400D DAYLIGHT HMI FIXTURE**

Contents

1. Important information	3
2. General description of the system	3
3. Safety precautions	4
A) Caution: mains voltage!	5
B) Distance to flammable materials	5
C) Outdoor operation	5
D) UV risk	5
E) Cooling	6
F) Repair and maintenance	6
G) Additional precautions	7
4. Power factor correction (PFC)	7
5. Installing lamps	7
6. Stand fitting	8
7. Starting operation of the system	9
8. Operational elements	10
9. Adjusting light intensity	11
10. Transport	11
11. Connection diagram: Ballast and the light head cable	12
12. Technical data - Specifications	13
13. Trouble shooting	14
14. Warranty	15

1) IMPORTANT INFORMATION

Read all of the following information carefully before operating the Dedolight DEB400D electronic ballast and DLH400D daylight fixture.

This document contains important information regarding safety, operation and maintenance of this system.

This equipment is intended for professional use and is to be used by trained personnel only.

Keep the operating instructions with the equipment at all times.

The manufacturer is not responsible for damage caused by improper use or mishandling.

The DEB400D electronic ballast and the DLH400D light head are built in accordance with CE and EMV-regulations EN 55015, EN 61547, EN61000-3-2 and -3, safety standards EN 60598-1, EN 60598-2-17, EN 60922, EN60350 and cETLus complies to the UL1573 standard.

NOTE: This equipment has been tested and found to comply with the limits for a class A digital device, pursuant to Part 15 of the FCC rules. These limits are designed to provide reasonable protection against harmful interference when the equipment is operated in a commercial environment. This equipment generates, uses, and can radiate radio frequency energy and, if not installed and used in accordance with the instruction manual, may cause harmful interference to radio communications.

This equipment also complies with the technical requirements for a class B device.

2) GENERAL DESCRIPTION OF THE SYSTEM

The compact DEB400D electronic ballast is intended exclusively for use with the Dedolight DLH400D daylight light head.

The DEB400D electronic ballast is equipped with active power factor correction.

The light head is to be used with a 400W HMI lamp which provides the highest possible color rendition index $RA > 95$, and a color temperature of approximately 6000K.

The Dedolight DEB400D electronic ballast offers the capability of dimming the lamp, boosting the lamp or operating it with nominal power.

Further advantages of this electronic ballast in comparison to conventional ballasts for HMI lamps:

- flicker free up to 10,000 frames/second
- no camera synchronization necessary
- stable optimal color quality
- flicker factor of emitted light below 3%
- stable color temperature

- wide range of input voltages from 90-264V AC
- fluctuations of input voltage and input voltage frequency within the above-mentioned limits have no influence on the emitted light
- over voltage cut off
- automatic fuse in the mains switch
- active power factor correction

The lamp is driven with a square wave AC voltage of approximately 140 cycles. Lamp output is regulated according to preadjusted value independent of mains and lamp voltage. Lamp voltage and lamp amperage are also regulated, further contributing to flawless operation.

The power electronics is monitored by a temperature control circuit. Should cooling be insufficient or in case of fan failure, the electronic ballast will switch the lamp off. The ignitor is placed in a housing underneath the lighting fixture. The ignitor generates the ignition voltage necessary to start the lamp.

Push buttons on the ignitor housing and/or identical push buttons on the electronic ballast allow the start and stop of operation on the ballast or on the fixture.

Independent from the settings on the electronic ballast, the focusing knob on the light fixture allows the variation of the beam angle in an extremely wide range. Using a patented two lens system in combination with a 3-step movement of the mirror and lenses, it is possible to achieve a focusing range unprecedented in other compact light heads.

The finely tuned optical system offers an extremely clean beam - with practically no stray light - improved light distribution in spot and flood and any position in between. The adjustability of the beam has been enhanced by a super spot and super flood position.

The holders on the front ring of the fixture accept accessories such as the barndoor, filter holder or projection attachment which are secured by a latch on the left side of the fixture.

A handle on the rear side of the fixture, which can be unfolded for operation or folded for transport, allows for easy pan and tilt motions of the light head. Two openings on the stand fitting accept a safety wire or safety chain which is necessary when the fixture is operated in a hanging mode. A metal noose on the right side of the light head can accept a suitable safety cable or safety chain to connect the light head with its point of fixation when operated in a hanging mode. If needed, the same noose can be used for a safety cable to secure the barndoor.

3) SAFETY PRECAUTIONS

The DLH400D daylight light head cannot be operated without the DEB400D electronic ballast. The connecting cable (DPOW400D) must be used between the electronic ballast and the light fixture. **Maximum tilt angle is +/- 90°.**

Upside down operation of the light head is not allowed and will damage the ignitor.

A) CAUTION: MAINS VOLTAGE!

This system is built according to Safety Class 1 which requires a grounded 3-pin connection (L, N, PE). Before connecting the ballast to the mains, be sure the outlet meets safety regulations. If the ground connection carries any voltage, the outlet should not be used under any circumstance. If the ground connection is missing, a suitable grounded outlet must be found.

Care should be taken to ensure that the mains connector and mains cable are of a suitable dimension (gauge) to meet the prevailing rules in each individual country. The electronic ballast works with all voltages from 90-264V AC.

B) DISTANCE TO FLAMMABLE MATERIAL

The light head must never be operated near flammable material.

Minimum distance to flammable material in direction of the emitted light: 1,5m (5 ft).

Minimum distance of the light head housing to flammable material: 0,4m (1,4ft).

The system must not be switched on or used in aggressive or explosive media.

Caution: Do not put light into transport case while still hot !!

C) OUTDOOR OPERATION

The electronic ballast DEB400D is built according to Safety Class IP20 and is therefore not suitable for use in wet or high humidity surroundings.

The fixture (light head) is built according to Safety Class IP21 which allows it to be used in light drizzle (straight downward falling drops) but it must not be exposed to rain when switched off.

The light head cable and connectors are in accordance with IP67 and can be laid on wet ground provided correct seating of the connector lock rings is assured.

D) UV RISK

The lamp used in the light head emits high UV values which present a health hazard if proper protection is not ensured. Do not operate the system if:

- the roof of the fixture is open
- there is no front lens in the light head
- the front lens is without UV cut filter
- there is no mirror inside the light head
- internal protective shields are missing or damaged

E) COOLING

DEB400D ELECTRONIC BALLAST:

The sides of the housing of the electronic ballast are built as cooling elements. Cooling ribs must not be covered or obstructed in any way. The double back plate serves as air intake and must not be covered or obstructed. The air outlets on the side vents must allow unhindered exit of warm air.

The electronic ballast must not be operated on humid or wet surfaces.

Avoid direct sunlight on the DEB400D.

DLH400D DAYLIGHT FIXTURE:

To prevent the possibility of fire, the DLH400D light head must be mounted on a light hanger suitable for the load or on a lighting stand of suitable dimension to prevent the light head from falling or tipping over.

Do not cover the air intake or air exit openings or place any object on top of the light head.

F) REPAIR AND MAINTENANCE

Repair, maintenance and adjustments are only to be conducted by Dedotec's repair department or qualified service personnel. Only manufacturers original replacement parts are to be used.

Mains input and output of the electronic ballast are not isolated.

Extreme care must be taken when taking measurements on the ballast or light head with power applied.

No grounded measuring instruments should be used and all relevant safety precautions must be observed. The ignitor produces dangerously high voltages up to 30KV!

Disconnect head from ballast before performing the following inspection.

The high voltage cables (between the ignitor and the socket) and the sockets themselves must be visually inspected at least once a year (view through opened roof of the fixture). Even if only minor mechanical damage has occurred, these components must be replaced.

Every 100 hours of operation, the lamp must be checked. Damaged or deformed lamps must be replaced to minimize the risk of exploding lamps.

Before each operation of the system, the condition of the front lens must be checked. A broken front lens must only be replaced by an original front lens with UV cut filter (recognizable by a purple coloration when looked at from an angle).

G) ADDITIONAL PRECAUTIONS

- Switch equipment off when not in use
- Don't carry the equipment by its power cable
- Don't squeeze cables underneath doors
- Don't place cables over sharp objects
- In case of malfunction, disconnect ballast from mains (don't pull on the cable)
- Do not allow children to operate the ballast
- Make sure that damaged equipment is rendered inoperable and properly disposed of or sent to the manufacturer for repairs

4) POWER FACTOR CORRECTION (PFC)

The built-in active power factor correction (PFC) reduces the idle power (reactive power) in the electronic ballast and regulates automatically to $\cos \varphi$ (cos Phi) 0.99. Because of this, the current consumption is reduced by approximately 30 - 35% in comparison with traditional ballasts. On a 120V outlet with a 15A automatic fuse, it is possible to use two DEB400D electronic ballasts instead of only one.

An additional advantage is the continuous range of input voltage from 90 - 264 AC.

5) INSTALLING LAMPS

- A)** Put red mains switch on ballast to off position "O".
Disconnect ballast from mains.
- B)** After switching off the light fixture, allow the lamp to totally cool before attempting to change the lamp. Wait at least fifteen minutes to minimize the danger of an exploding lamp. Open the roof of the fixture with red sliding latch and fold the inner light shield housing forward.

CAUTION: The lamp may still be very hot.
Use heat insulated gloves.

C) Use only the following lamps:

Use of original Dedolight lamps is recommended: type **DD400HR** with blackened tip. This lamp matches perfectly the intricate design of the Dedolight optics. Furthermore the blackened tip eliminates imperfections in the spot position. Using the original Dedolight DD400HR lamp offers optimal results throughout the entire focusing range.

In case of emergency standard lamps 400 W single-ended hot-restrike can be used, for example:

Sylvania BA400 SE-HR

Osram HMI 400/SE

D) When installing a new lamp, do not touch the glass envelope of the lamp with bare fingers. Oil and grease residue burn into the quartz housing and lower the life expectancy. Remove the foam or plastic safety cover of the lamp only after placing it in the socket or touch lamp only with a lint-free cloth. If the glass housing is dirty, it may be cleaned off with a soft cloth and pure alcohol.

Make sure that the lamp is seated all the way down in the socket and both holding springs on the socket sit properly in the lamp.

Follow precautions as described in 3 F.

After inner housing has been folded back and the roof has been closed, the red latch must engage audibly.

Average lifetime of the 400W metal halogen lamp is about 650 hours. This refers to a cycle of three hours on and one hour off.

Frequent on/off switching, dimming or use in boost "☉" position shortens lamp life.

The probability of an explosion of the lamp is very low. However, if the average lifetime is exceeded by more than 25%, the risk of a lamp explosion noticeably increases.

6) STAND FITTING

Both stands with 5/8" (16mm) stud and 1 1/8" (28mm) receptacle can be used with the dedolight Series 400.

The 400D lighthouse comes prepared for use with a stand with a 5/8" stud. In order to use the stand with the 1 1/8" (28mm) receptacle, the holding screw (A) is removed and parked in a thread on the yoke (B). See drawing on the bottom of page 10.

7) STARTING OPERATION OF THE SYSTEM

- Check to make sure that red mains switch is in off position “O”.
- Connect light head (with lamp installed) to ballast with 7m connecting cable.
- Connectors are to be secured by the locking rings.
- Connect ballast with mains cable to a suitable outlet (as described in 3A).
- Switch ballast on (mains switch). Presence of power is indicated by light in the switch. Ballast is now in ready state.
- If the system is correctly connected and the roof of the light head is closed, the “READY” indicator lights on the ballast and on the light head are illuminated green.
- The lamp can be ignited using the green push button (START) on the ballast or on the lighthouse.
- Once the lamp has been ignited, the control indicator (LAMP) lights up.
- The run up phase of a metal halogen lamp to full brightness can last up to three minutes.
- Switch the lamp off by pushing red push button (STOP) on the ballast or on the light head.

CAUTION:

Switching off the metal halogen lamp during the run up time, shortens bulb life. This also causes a dark deposit on the inside of the lamp envelope and ignition will be more difficult or even impossible.

- When the electronic ballast is in ready mode, the lamp can be reignited in hot state.
- To conclude operation, switch ballast off on mains switch.

8) OPERATIONAL ELEMENTS

DEB400D

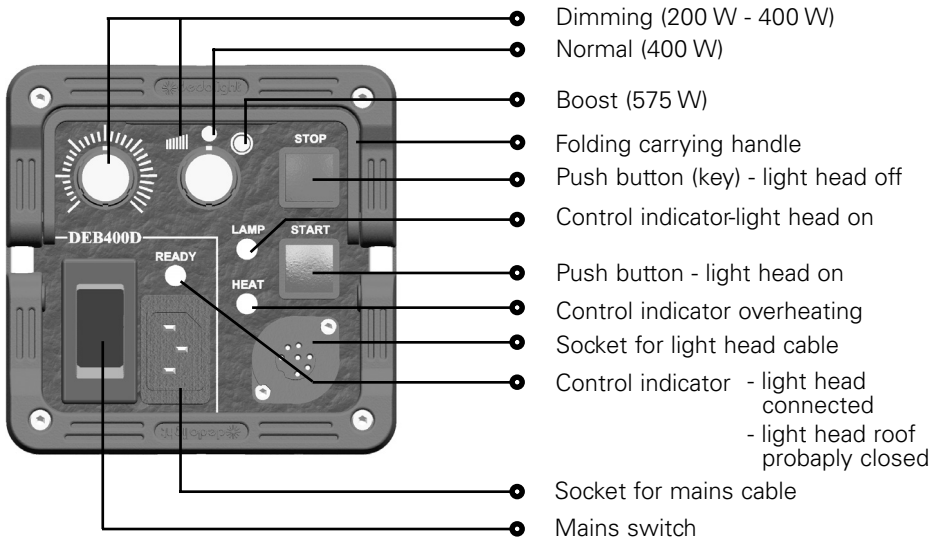

DLH400D

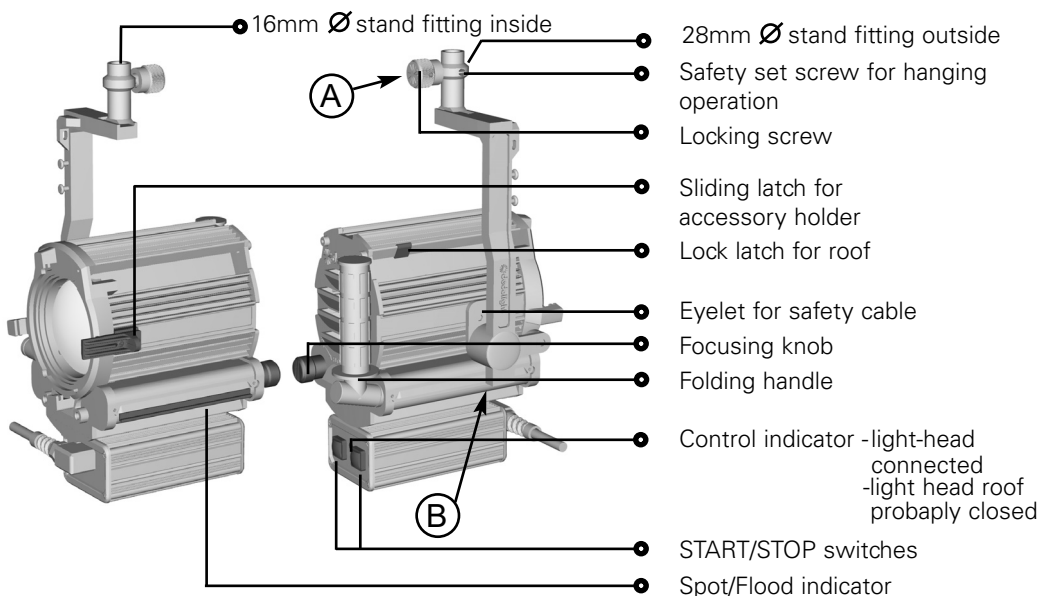

9) ADJUSTING THE LIGHT INTENSITY

Advantages of the 400W metal halogen lamp:

- drive in boost position (575W)
- drive in nominal position (400W)
- drive in dim position (200-400W)

Boost Position (140%)

The DEB400D electronic ballast may be set to the boost position "☉" by the yellow three position switch. This pushes the lamp from 400W to 575W. Even with increased intensity, the color temperature stays practically constant.

The lamp can be used continuously in boost position "☉" but lamp life will decrease.

Nominal Power (100%)

The optimum operating mode of a metal halogen lamp is at nominal output, i.e., switch position "●":

The metal halogen lamp is regulated to a constant power of 400W which meets lamp manufacturers' recommendation.

Dimming (50-100%)

Dimming is possible with the yellow three position switch set to dimming position "⦿". When in dimming position, the light intensity can be regulated on the left knob "☼" from 200 - 400W.

This regulating knob is only operational when the three position switch is in the dimming position "⦿".

When dimmed electronically, the lamp is not in an optimum operational state.

Operating in dimming position will not lengthen lamp life.

10) TRANSPORT

The Dedolight metal halogen lamps are delivered in a foam protector within a cardboard carton. This material was chosen in order to minimize damage from strong vibration.

The lamp should not be removed from the light head before transport, If the lamp fixation is fitted with the knurled screw (above the mirror).

Caution:

Lamp must be fully seated in the lamp socket with retaining springs engaged. Do not operate fixture without lamp or with improperly installed lamp. Failure to follow these instructions may cause damage to lamp & socket which is not covered under warranty.

11) CONNECTION DIAGRAM: BALLAST AND THE LIGHT HEAD CABLE

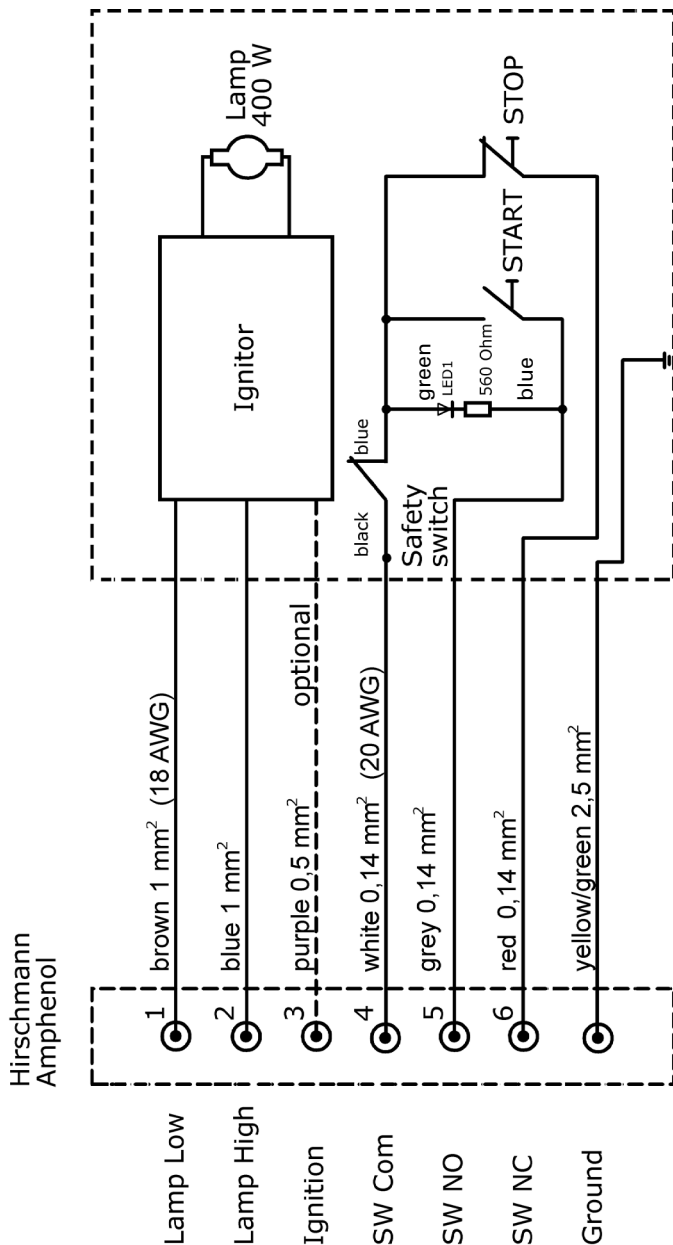

12) TECHNICAL DATA (SPECIFICATIONS)

General:

Manufacturer:	DEDOTEC optronische und mechanische Systeme GmbH		
Model/Type:	DEB400D (ballast); DLH400D (light head)		
Lamps:	DD400HR, BA 400 SE-HR, HMI 400 SE		
Standards:	EN 55015, EN 61547, EN 61000-3-2 and -3, EN 60598-1, EN 6598-2-17, EN 60922, EN 60950, CE, cETLus to the UL 1573 standart, FCC Part 15 (Class A and B)		
Electrical Safety:	Safety Class 1		
Prot.Class:	DEB400D:	IP 20	
	DLH400D:	IP 21	
	DPOW400D:	IP 67	

Weights and Measures:

Dimensions:	DEB400D:	H = 237 mm (9.3"), L = W = 128 mm (5.1")
	DLH400D:	H = 404 mm (16"), L = 250 mm (9.8"), W = 218 mm (8.5")
	DPOW400D:	L = 7m (23')
Weight:	DEB400D:	3.4 kg (7.5 Lb)
	DLH400D:	4.4 kg (9.7Lb)

Mains connection:

Input power:	700 VA (max.)
Input voltage:	115V - 240V AC
Functional range:	90V - 264V AC Over voltage cut-off integrated to mains switch cut out above 265V AC
Current consumption:	2,9 A (U = 240V AC); 6,9 A (U = 115V AC) at maximum lamp power (575W)
Mains frequency:	50 cycle / 60 cycle (47 - 65 cycle)
Power factor:	With active power factor corrections stabilized to $\cos\varphi$ 0.99
Efficiency:	Typically 0.86 (depending on lamp and mains voltage)
Operational temperature:	5°C to 35 °C (41°F to 95°F), max. 30°C (86°F) at U=90 - 105V AC
Storage temperature:	-20 °C to 80 °C (-4 °F to 176 °F)

Light head:

Lamp power:	Position 1: Dimming	(200 - 400W)
	Position 2: Normal	(400 W) +/- 5%
	Position 3: Boost	(575W) +/- 5%
Current:	Square wave current approximately 140 cycle	
Regulatory principle:	Power regulation with analog multiplier for lamp voltage range between 60V to 100V. In-rush and short circuit current limited to about 11A.	
Ignition:	Hot and cold start	
Light ripple:	< 3% flicker	
UV-radiation	max. 50 µW/lm	

13) TROUBLE SHOOTING

- A.** If the red indicator in the mains switch doesn't illuminate, the mains outlet or mains cable may be defective.
- B.** If the mains switch can't be switched on:
-mains voltage above 264V
-mains voltage has voltage spikes
-short circuit in the ballast.
- C.** If the "READY" control indicator on the ballast and on the light head doesn't light up, this indicates an interruption of the safety loop.
Possible causes:
-lock rings of cable connectors are not properly closed
-the lighthead roof is not closed.
- D.** If the red "HEAT" control lamp lights up, this shows overheating in the ballast.
Possible causes:
-ambient temperature too high
-ballast exposed to direct sunlight
-air intake and/or outlet slit openings on ballast are obstructed
-fan failed or is obstructed by foreign object.
-Solution: Eliminate cause and reactivate ballast after cool down period.
- E.** When pushing the start key, loud noises audible in light head.
Possible causes:
-no lamp installed.
-lamp not seated deep enough in socket
-lamp defective
-ignition cable or socket defective
- F.** Ballast switches off after a few minutes of light head operation.
Possible causes:
-lamp is at end of lifetime
-lamp damaged (i.e. cracks in the glass, blackened envelope, dirty or oxidized contact).
-ambient temperature of ballast is too high
-input voltage fluctuations exceed specified limits
- G.** If light head cable shows sharp bends or damage, broken leads could be the cause of malfunction.

In case of component failure: If none of the above mentioned faults can be detected, the entire system should be sent for repair.

14) WARRANTY

Dedotec GmbH warrants to the original purchaser, that this product is free from defects in material and workmanship and agrees to repair or replace, at its option, products which under normal installation and use discloses such defect, provided the product is delivered to Dedotec by the original purchaser, intact, for examination with all transportation charges prepaid along with a dated sales receipt, within one (1) year from the date of purchase from an authorized Dedotec dealer and provided that such examination discloses in the judgment of Dedotec that it is thus defective.

This warranty does not cover any equipment which has been subjected to misuse, abuse, neglect, incorrect wiring, improper installation, lightning or other incidence of excessive voltage or use in violation of instructions furnished by us nor to any equipment which may have been tampered with, altered or repaired by other than Dedotec or its authorized service agencies.

Dedotec is not responsible or liable for indirect, special, or consequential damages arising out of or in connection with the use or performance of the product or other damages with respect to any economic loss, loss of property, loss of revenues or profit, or costs of removal, installation or reinstallation.

Except as provided herein, Dedotec makes no express warranty, and any implied warranty of merchantability or fitness for a particular purpose is limited in its duration to the duration of the written warranties set forth herein.

Dedotec GmbH issues no warranty for the completeness of this document. Information in this manual and product is subject to change without notice or obligation.

Copyright Dedotec GmbH, 2000.
All rights reserved.

Service address:
DEDOTEC USA, INC.
216 Little Falls Rd.
Cedar Grove, NJ 00709
Phone: (973) 857-8118
Fax: (973) 857-3756



Service address:
DEDOTEC optical and
mechanical systems GmbH
Karl-Weinmair-Str. 10
80807 Munich
Phone: 089 / 356 16 01 Fax:089 / 356 60 86